



System Installation

Manual

Version 3.1.6

POLYTRONICS ENGINEERING
referred to as PENG
Copyright PENG
©2006 All Rights Reserved

Installation:

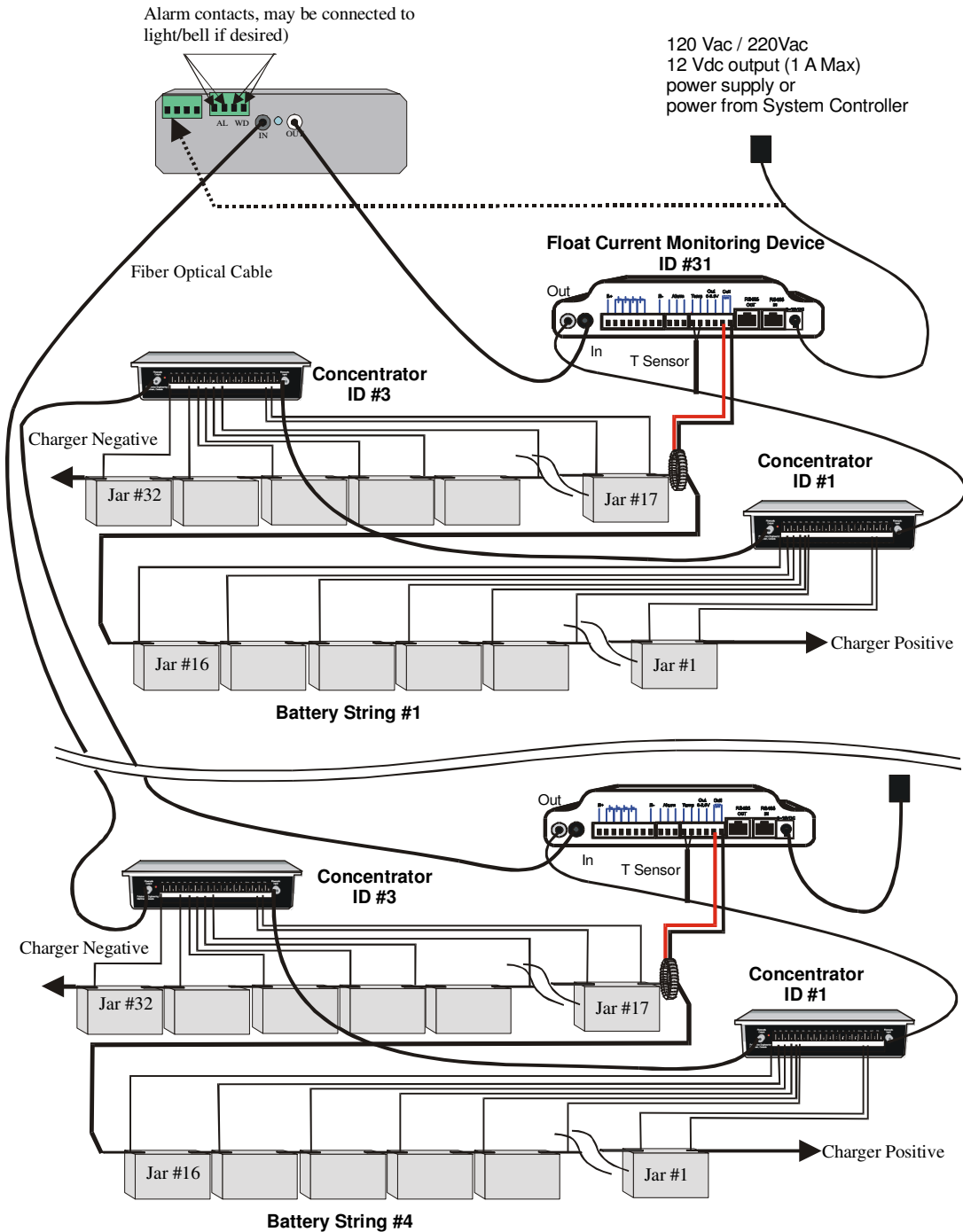

Figure 1: Diagram of typical Concentrator Connections

Installation

There are a few small differences in the equipment depending on whether the system is monitoring 2V or 12V cells. Although concentrators may look the same, it is important to check the nameplate to tell whether the concentrator has the proper voltage for your application. One low voltage concentrator (less than 6 volts per cell) can serve up to 15 cells if the intercell resistance and internal impedance of the cell are measured separately or up to 30 cells if intercell resistance is measured together with the internal cell impedance. One high voltage concentrator (greater than or equal to 6 volts per cell) can serve up to 10 cells if the intercell resistance and internal impedance of the cell are measured separately or up to 20 cells if the intercell resistance is measured together with the internal cell impedance. See Figure 1.

The concentrator can be calibrated to any standard jar voltages from 1.2V to 12V, providing that the total voltage per concentrator does not exceed 240V.

1) All the cell numbers noted here are in reference to the most positive end of the string. The cell at the most positive end of the string will be called Cell #1 and then counted sequentially.

2) Before installing the Float Current Device, make sure that proper steps have been taken with the critical load so that when the string is open, the system will not be affected

When a Float Current Device is used, install it on the most positive post of the battery string. Bus bars may have to be reworked in order to fit the transducer. Make certain to re-torque all the bolts loosened after connecting the transducer.

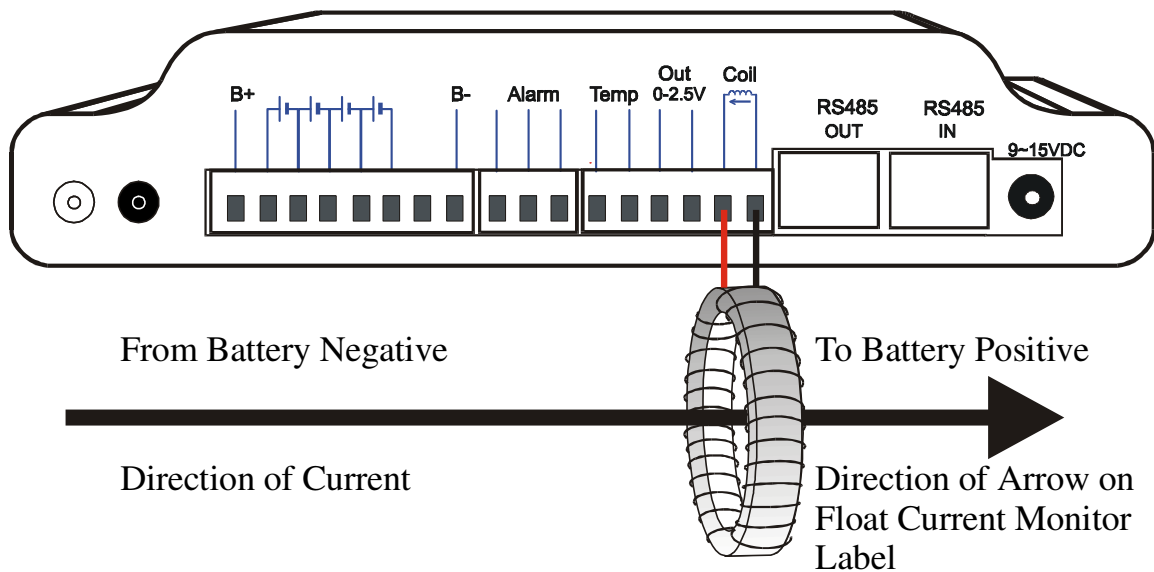

Fig 2: Showing the connections to measure current using Float Current Device

IMPORTANT. After full system installation, please clear Float Current Monitor Data memory (see appendix B).

3) Run the plastic wiring duct along the battery rack rail with the outlets positioned at each battery cell pair, see Fig. 3. You may substitute the wiring duct with plastic conduit if necessary.

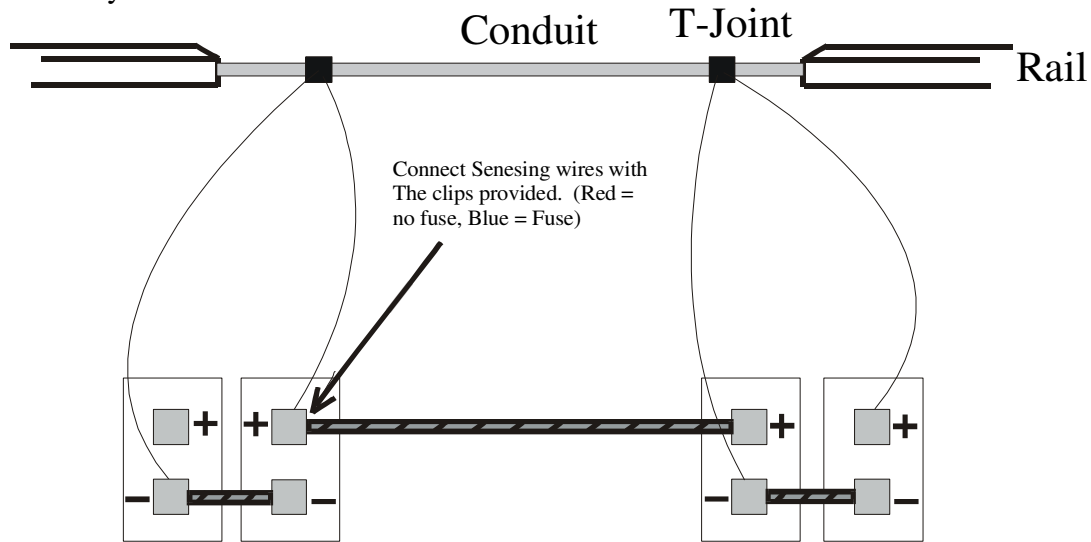

Fig. 3

4) Typically, the concentrators are installed as a wall mount or under the upper battery rack at 30 cell intervals as shown in Fig. 4. If there were a more suitable location for the concentrators than other than the wall inside the battery room or the battery racks, this would also be acceptable. Make sure that wherever the concentrator is installed, it is held in place firmly.

Each concentrator is uniquely identified by the concentrator number, which is displayed on the nameplate. The concentrator must be installed sequentially. Refer to the accompanying wiring chart/diagram for recommended positions.

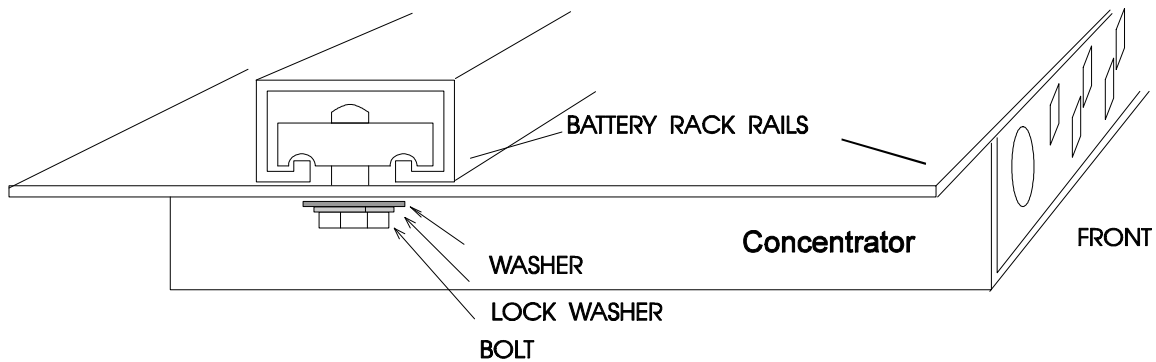

Fig. 4a: Concentrator Battery Rack Installation (side view)

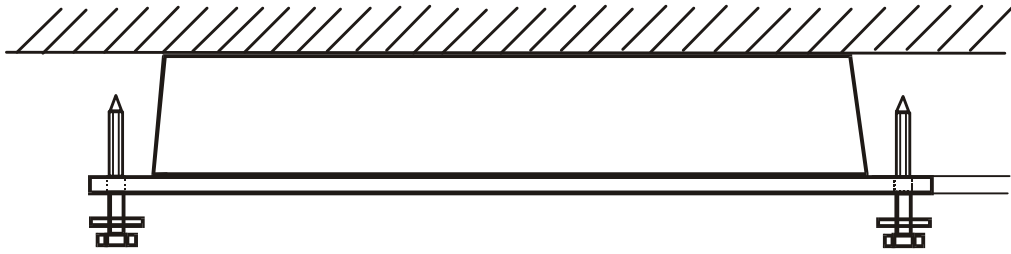

Fig. 4b: Concentrator Wall Installation (top view)

5) Following the wiring chart, connect the concentrator terminals to the battery. At the concentrator end, crimp the female fast-on connectors to the AWG18 wire. Run the wire via plastic wiring duct to the corresponding battery. You may have to use cable ties to keep the wiring in place. For the connection at the battery, the wire should be placed inside the quick disconnect of the appropriate battery cell. Connect the pigtail to the quick disconnect as shown in Figure 5. Remember that there are two types of battery clips.

It is important to remember that there are two types of battery clips. One type is blue and contains fuses and the other type is red and contains current limiting resistors. Again, refer to the wiring chart to determine which one to use. It is highly advisable that all wires should be labeled at each end of the cable. These labels are provided with each system.

Figure 4: Sensing Wire Battery Connection

Sensing wires are to be connected to the fast-on connectors located on the front of each concentrator. Follow the wiring chart and tag the wires accordingly.

WARNING: If there is a switch on the concentrator, make sure it is in the off position before making any connections. Also, work from the right connectors to the left, insuring that the (B-) connection is the last one to be connected. This will provide power to the concentrator. Do not connect it until you are able to run Utility program (see Operation and Setup Manual).

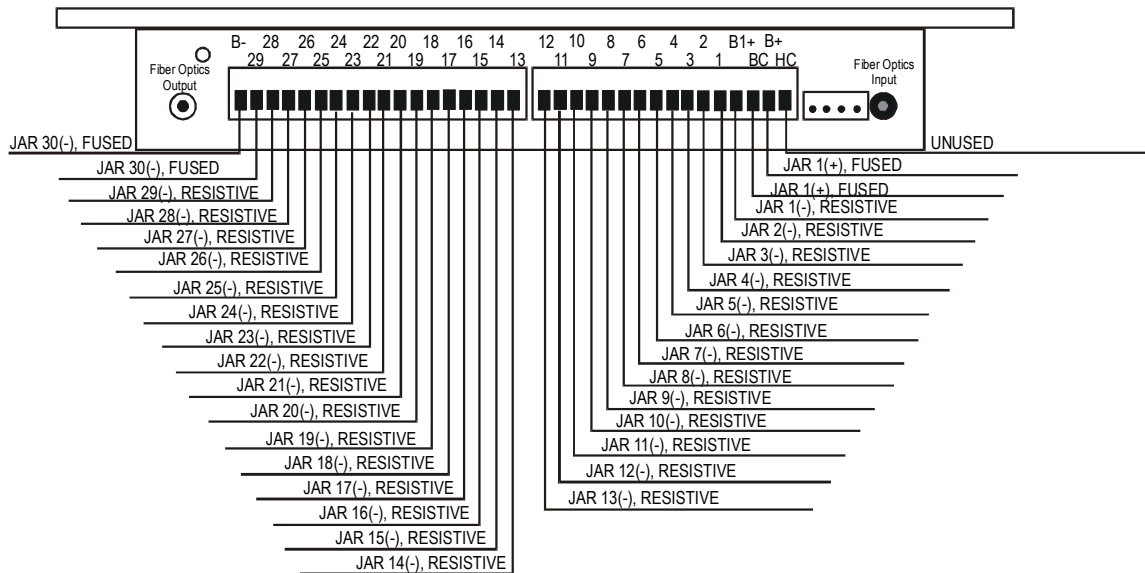

Figure 6: Cell/Jar Inputs

6) Connect the concentrators using the Fiber Optic Cables. They are connected in a daisy chain format with the FIBER-out of one concentrator connected to the FIBER-in of the next concentrator. **Note: Neither the sequence nor the total length of the cable is important. The only important aspect is the length of the longest piece of the cable is.** The FIBER-OUT of the last concentrator of the fiber optic link is connected to the Fiber I/O unit which is connected to the fax modem. Plug this cable into the INPUT. The OUTPUT is connected to one of the concentrators of the string's FIBER-IN. Plan your connections of the fiber optic cables to minimize the length of the longest fiber optical run. See Fig. 7.

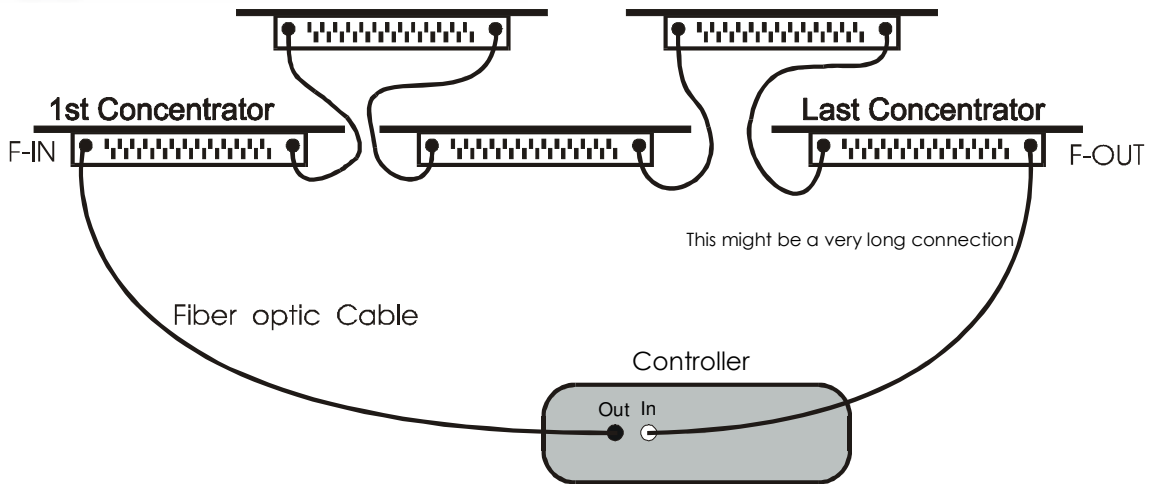

Fig. 8: All fiber optic cable runs should be no more than 100ft/33m

If you are monitoring several strings at once, through multiple concentrators, and you wish to separate one or several strings/concentrators, it is simply a matter of re-arranging the fiber optic setup.

Compare this picture to the one above to see how a concentrator can be extracted from the loop for maintenance, or repair. Re-arranging the fiber optic cables will result in a temporary loss of communication.

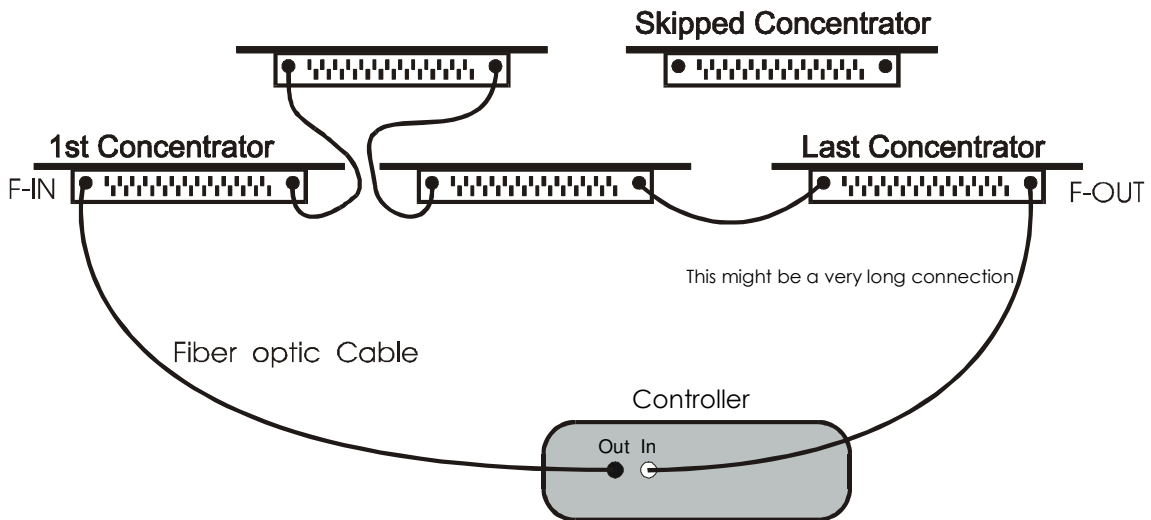

Figure 9

Setup and Configuration

For configuration and setup of the system, see the **Operation and Setup Manual** for the controller.

Running Fiber Optic Cables

Keep the radius on all bends at least 2 inches or 40 mm. Fiber optic cables can only be joined using special tools. Care should be taken to run all lengths prior to cutting.

Terminating Fiber Optic Cables

The fiber optic cable from the concentrators should be terminated in the appropriate socket in the RS-232 converter unit. The converter should be located close to the computer and modem. Prepare the end of the fiber optic cable by cutting it at a right angle with a sharp utility knife. The outer covering should then be stripped back for a length of 0.15 inches or 3 mm. To smooth off the fiber optic for better light transfer, heat the blade of the utility knife for a few seconds and then place it on the end of the fiber cable for about 1 second. This will leave a shiny flat end on the cable. Position the prepared end of the fiber optic cable in the input (or output) of the special fiber optic's connector, be sure the connector is loosened. Push the end of fiber optics cable into the housing, tighten the connector with finger force as would be used to close a toothpaste container.

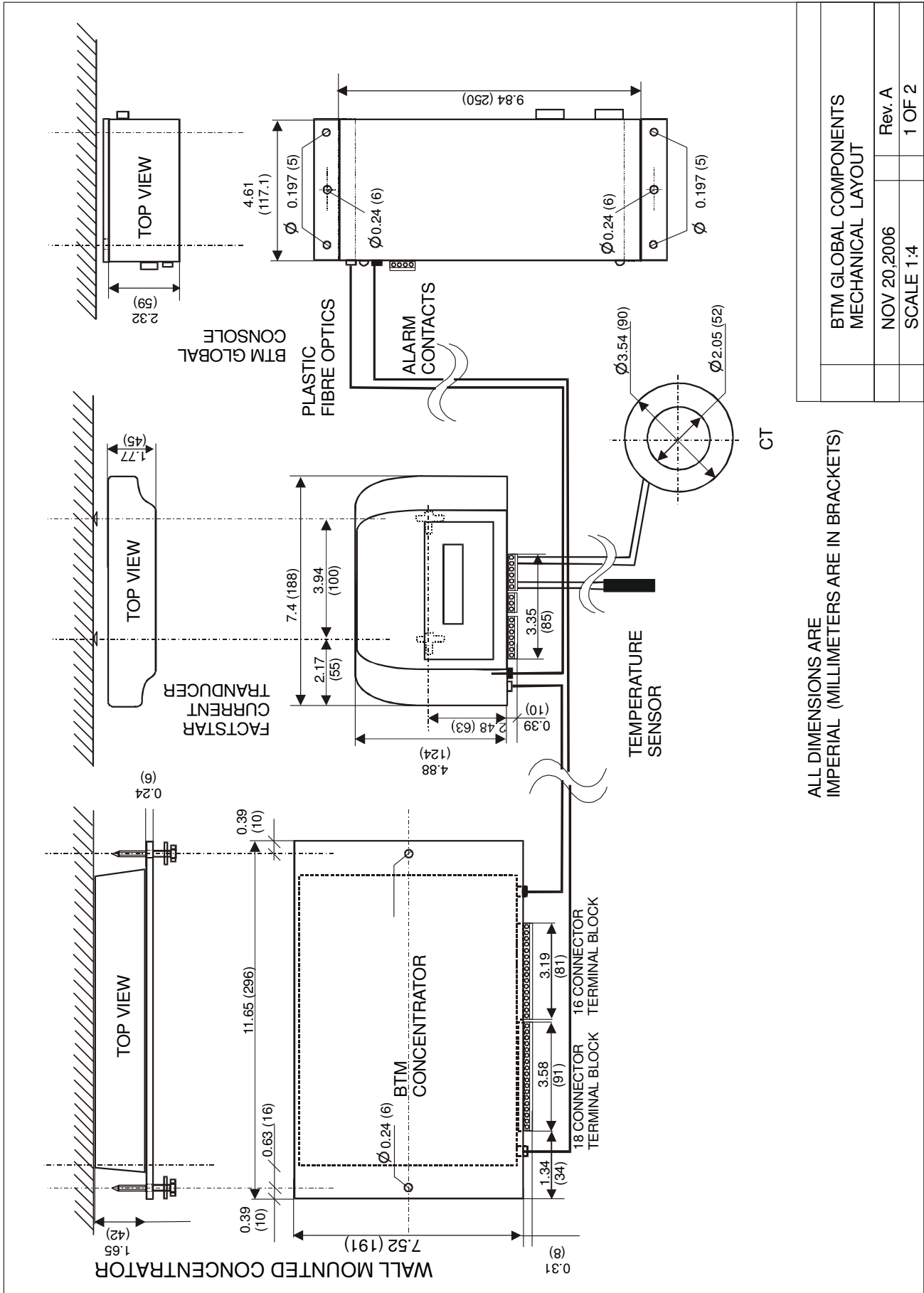

ALL DIMENSIONS ARE IMPERIAL (MILLIMETERS ARE IN BRACKETS)

BTM GLOBAL COMPONENTS MECHANICAL LAYOUT	
NOV 20, 2006	Rev. A
SCALE 1:4	1 OF 2

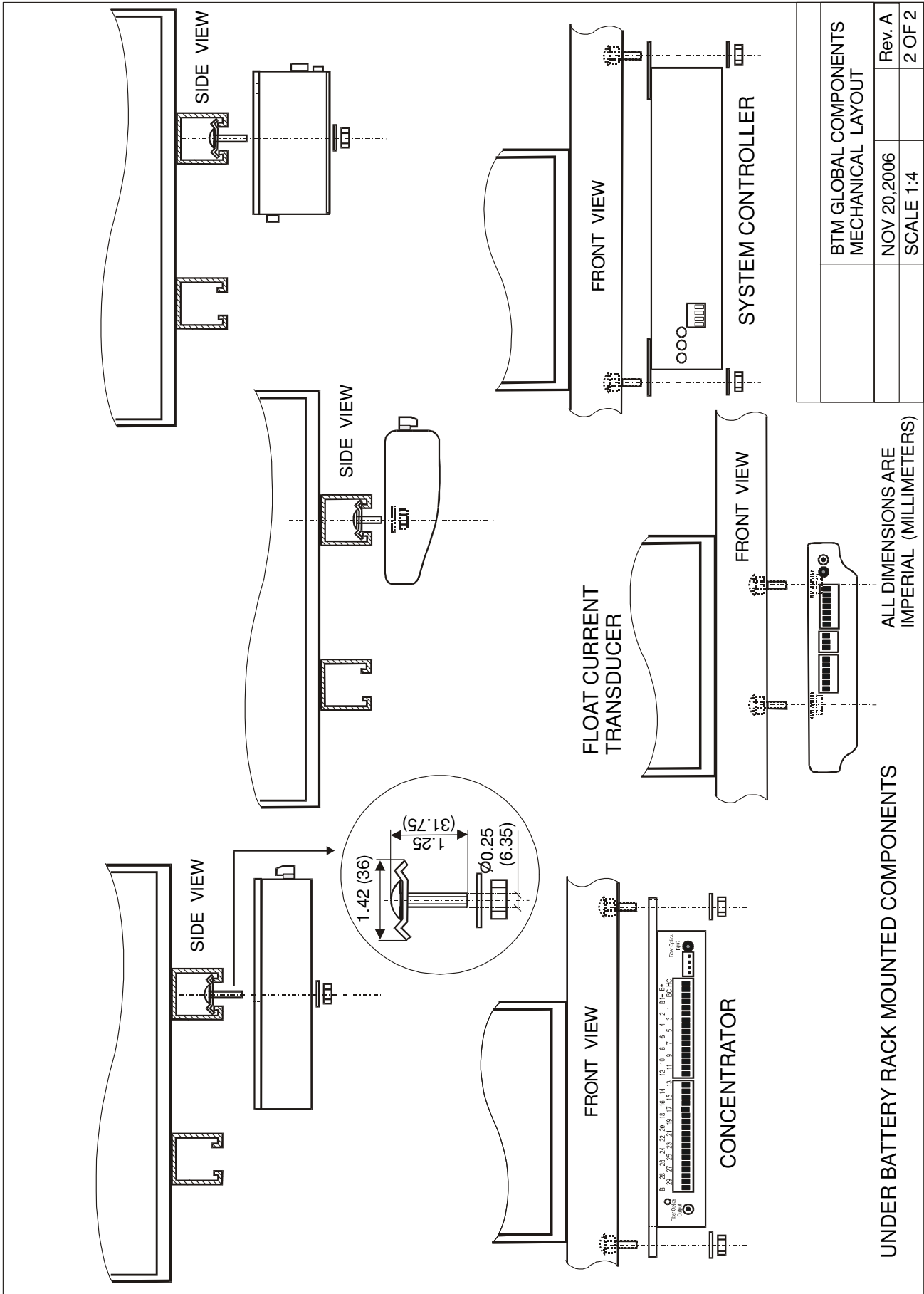

BTM GLOBAL COMPONENTS MECHANICAL LAYOUT	Rev. A
NOV 20, 2006	2 OF 2
SCALE 1:4	

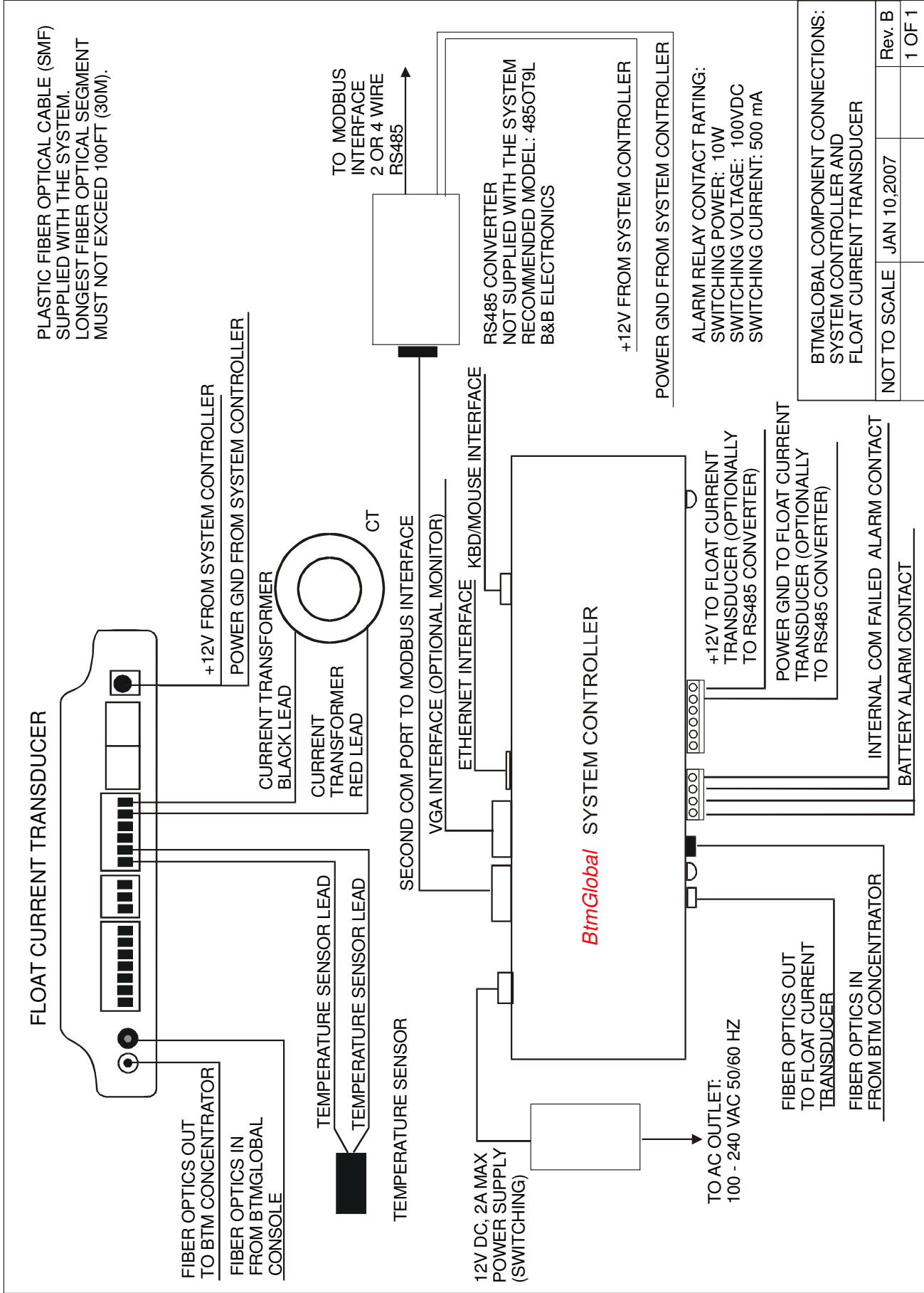

NOT TO SCALE	JAN 10, 2007	Rev. B
		1 OF 1

Clearing Float Current Monitor Memory.

The Float Current Monitor (FCM) keypad has 4 buttons, under the LCD screen.

The **SEL/ALT** key will take you from one menu level to another.

The **Reset/↑**, and the **Funct/↓** keys are used to scroll through the sub-menus on the same menu level.

The **ON/CLR** button is an exit button. While in a menu, you can press this button to return to the default status screen.

The menu structure for the FCM is presented in Figure B1.

Figure B1: LCD Menu Structure

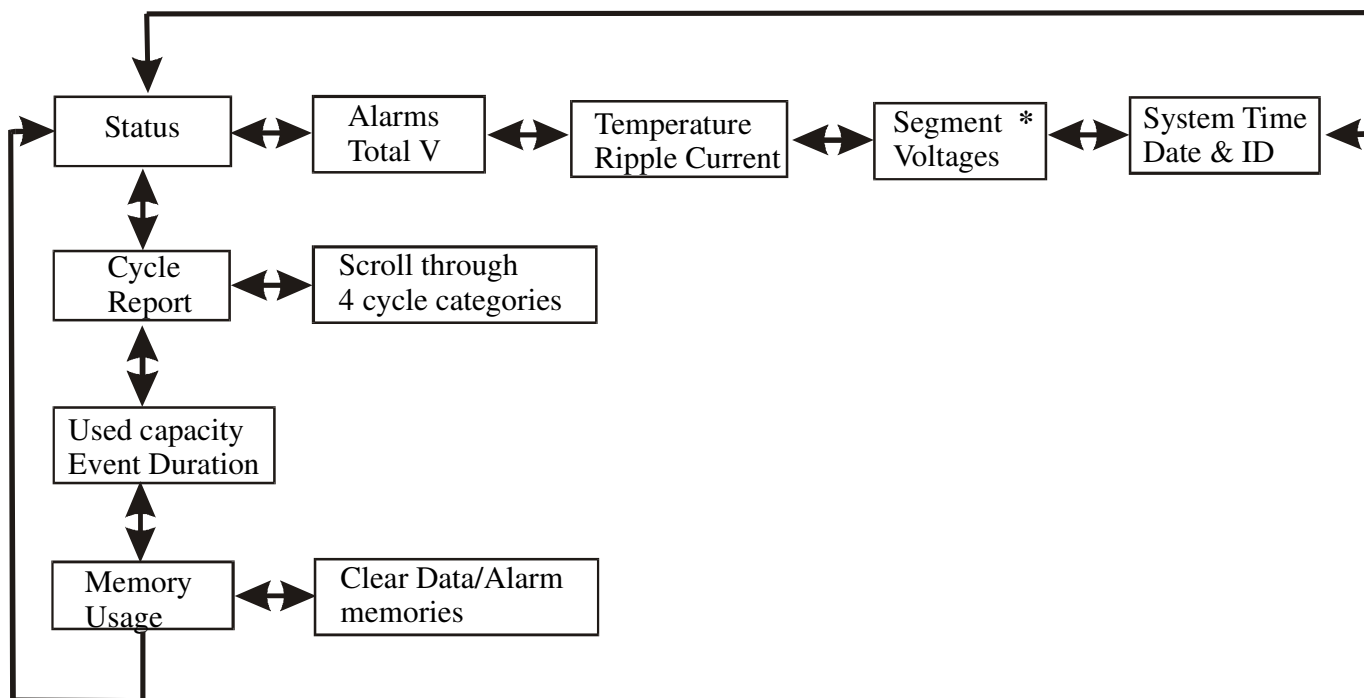

By pressing **Funct/↓** key while at fourth level menu, will result a Memory Clear Prompt appearing on the FCM LCD. To clear memory, just press the **ON/CLR key** while “**To erase Mem, Press [CLR]**” message is displayed on the Factstar LCD. This will clear **all** stored data and alarms.

Hence, to clear FCM data, follow the following key-press sequence when Main menu screen is displayed (Status and current reading screen), as shown below.



- Press **SEL/ALT 3 times** (on LCD should read as shown below)
ALARMS: XXX
DATA : YYY
- At this screen, press **Funct/↓** key, following string should appear:
To erase Mem
Press [CLR]
- Now press **ON/CLR** - data and alarm memories will be cleared.